

INSTALLATION INSTRUCTIONS

Item#511/512/513/514-84/66A/787-L

READ AND SAVE THESE INSTRUCTIONS

WARNING! SHUT POWER OFF AT FUSE OR CIRCUIT BREAKER.

AVERTISSEMENT! COUPER LE COURANT AU NIVEAU DES FUSIBLES OU DU

READ AND SAVE THESE INSTRUCTIONS

PREPARATION

1. Shut off power at the fuse box or circuit breaker box and remove the old fixture including the mounting hardware.

2. Carefully unpack your new fixture and lay out all the parts in a clean area. Take care not to misplace any small parts necessary for installation.

INSTALLATION & ASSEMBLY (Fig.1)

3. An octagonal junction box must be installed at each desired location, before installing fixture. The box must have a depth of at least 1/2".

4. Pull power supply wires from junction box through the center opening of mounting plate.

5. Attach mounting plate (A) to junction box, make sure mounting plate is flushed and leveled before tightening with Junction box screws (B).

6. Follow Fig.1 in the correct direction, clamp canopy (C) to mounting plate (A), and then lock it with screws (D).

7. Make electrical wiring connections between fixture and power supply (see ELECTRICAL WIRING below).

8. After the wiring is complete, place fixture in the correct position onto canopy (C), making sure the 2 sides are stuck.

9. Lock the fixture screws (E).

ELECTRICAL WIRING (Fig. 2)

Strip 3/8" of bare power supply wires from junction box.

Follow the wiring connection guide to connect wires from fixture to power supply wires from junction box, using wire nuts.

Connect neutral wire (white) from junction box to neutral wire (white) from fixture.

Connect hot wire (black) from junction box to live wires (black) from fixture.

Connect green ground wire from fixture to green or bare copper ground wire from junction box, using a wire nuts (D).

Once the connections are done, carefully push wires back inside junction box.

There are five CCTs (2700K / 3000K / 3500K / 4000K / 5000K) with this fixture. Select the desired CCT by using switch on canopy of fixture.

**Your installation is now complete.
Return power and test the fixture.**

IMPORTANT: FIXTURE SHOULD BE INSTALLED BY A QUALIFIED ELECTRICIAN TO ENSURE PROPER WIRING AND INSTALLATION.

Care and maintenance

Use a clean, soft cloth to wipe the surface of fixture.

DO NOT use any cleaners with chemicals, solvents, or harsh abrasives.

Dimming: Dimmable with ELV and/or LED compatible wall dimmer switches.

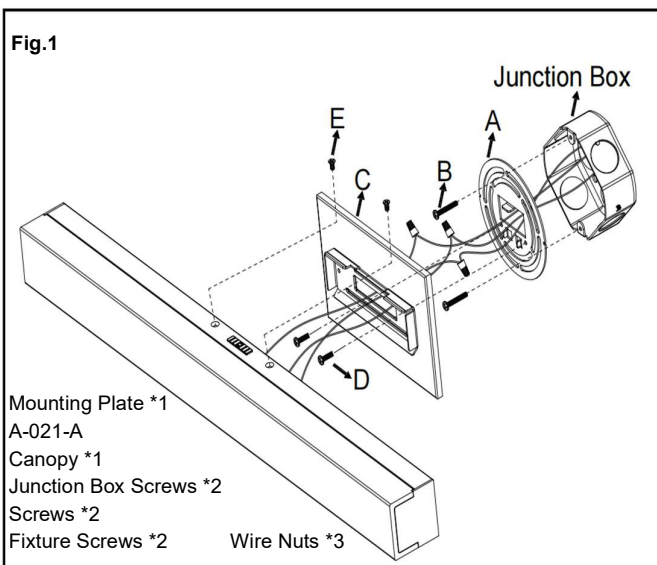

Fig.2 Wiring

Fixture Wires	House Wires
Black or Smooth	Black (Hot)
Fixture Wires	House Wires
White or Ribbed	White (Neutral)
Fixture Wires	House Wires
Bare wire (Ground)	Green or Bare Copper (Ground)